

**TIMKEN****The Timken Company**

4500 Mt Pleasant St. NW

N. Canton, OH 44720

Phone: (234) 262-3000

E-Mail: [CustomerCAD@timken.com](mailto:CustomerCAD@timken.com) • Web site: [www.timken.com](http://www.timken.com)

Part Number 3208 ATN1, Timken® Double Row Angular Contact Ball Bearings (3200, 3300)

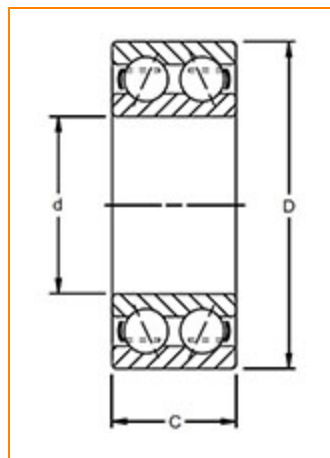
[Dimensions](#) | [Specifications](#) | [Basic Load Ratings](#) | [Abutment and Fillet Dimensions](#)

### Dimensions

<b>d - Bore</b>	40.00 mm 1.5748 in
<b>D - Outer Diameter</b>	80.00 mm 3.1496 in
<b>C - Ring Width</b>	30.2 mm 1.1890 in
<b>Contact Angle</b>	30°

### Specifications

<b>Features</b>	Open
<b>Ball Type</b>	STEEL
<b>Age Type</b>	Molded



Cage Material	Nylon
Bearing Weight	0.61 Kg 1.347 lb
Design Units	METRIC

### Basic Load Ratings

C0 - Static Radial Rating	31800 N 7147 lbf
C1 ISO - Dynamic Radial Rating	40200 N 9035 lbf

### Abutment and Fillet Dimensions

R - Inner Ring "To Clear" Radius <sup>1</sup>	1.10 mm 0.043 in
r - Outer Ring "To Clear" Radius <sup>2</sup>	1.10 mm 0.043 in
da - Inner Ring Backing Diameter	47.0 mm 1.850 in
Da - Outer Ring Backing Diameter	73.0 mm 2.874 in

<sup>1</sup> Maximum housing fillet radius that bearing corners will clear.

<sup>2</sup> Maximum shaft fillet radius that bearing corners will clear.

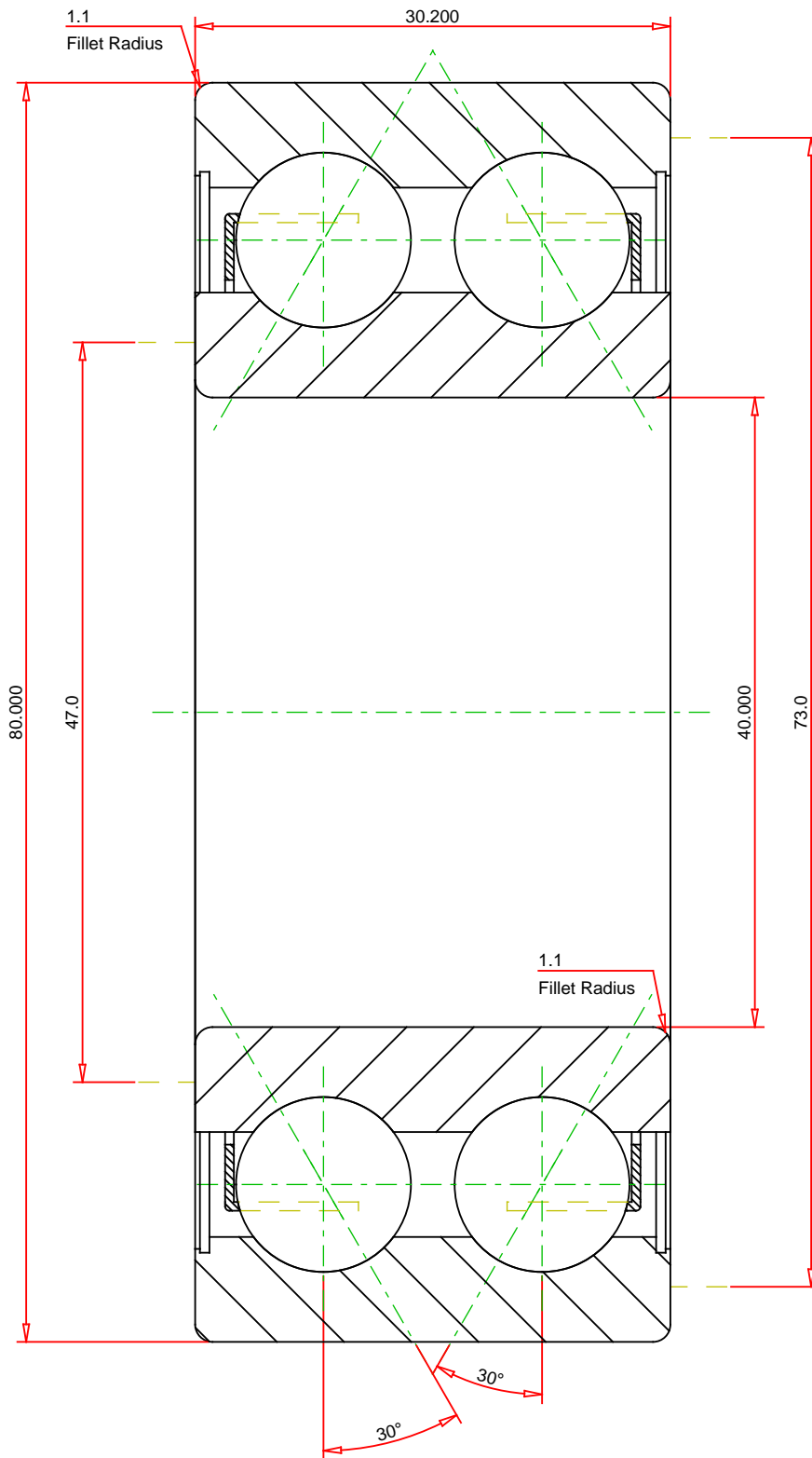

METRIC UNITS

Number of Balls Per Row	20
Bearing Weight	0.610 kg

**TIMKEN**®

---

**THE TIMKEN COMPANY**  
NORTH CANTON, OHIO USA

<b>3208 ATN1</b>	
Timken® Double Row Angular Contact Ball Bearings (3200, 3300)	
Dynamic Load Rating	40200 N
Static Load Rating	31800 N

Every reasonable effort has been made to ensure the accuracy of the information contained in this writing, but no liability is accepted for errors, omissions or for any other reason.

**FOR DISCUSSION ONLY**